

Hidden HPR-40 DSA Membrane Inlet Mass Spectrometer System for Dissolved Species Analysis



Introduction

The HPR-40 DSA Membrane Inlet Mass Spectrometer (MIMS) System is configured for real-time quantitative analysis of **dissolved or evolved gases and vapours**.

The inlet probe uses a permeable membrane that allows small levels of the dissolved species to pass through and on to the QMS.

The HPR-40 DSA system has a mass range of 200 amu (300 amu option) and **sub ppb detection levels**.

Interchangeable membrane inlet probe types address a broad range of applications.

Applications of HPR-40 MIMS

- Soil core analysis
- Fermentation process analysis
- Water analysis in Estuary, River or Reservoir
- Groundwater studies
- Methane production control
- Microbiological / Enzyme activity studies
- Environmental monitoring



MIMS Overview

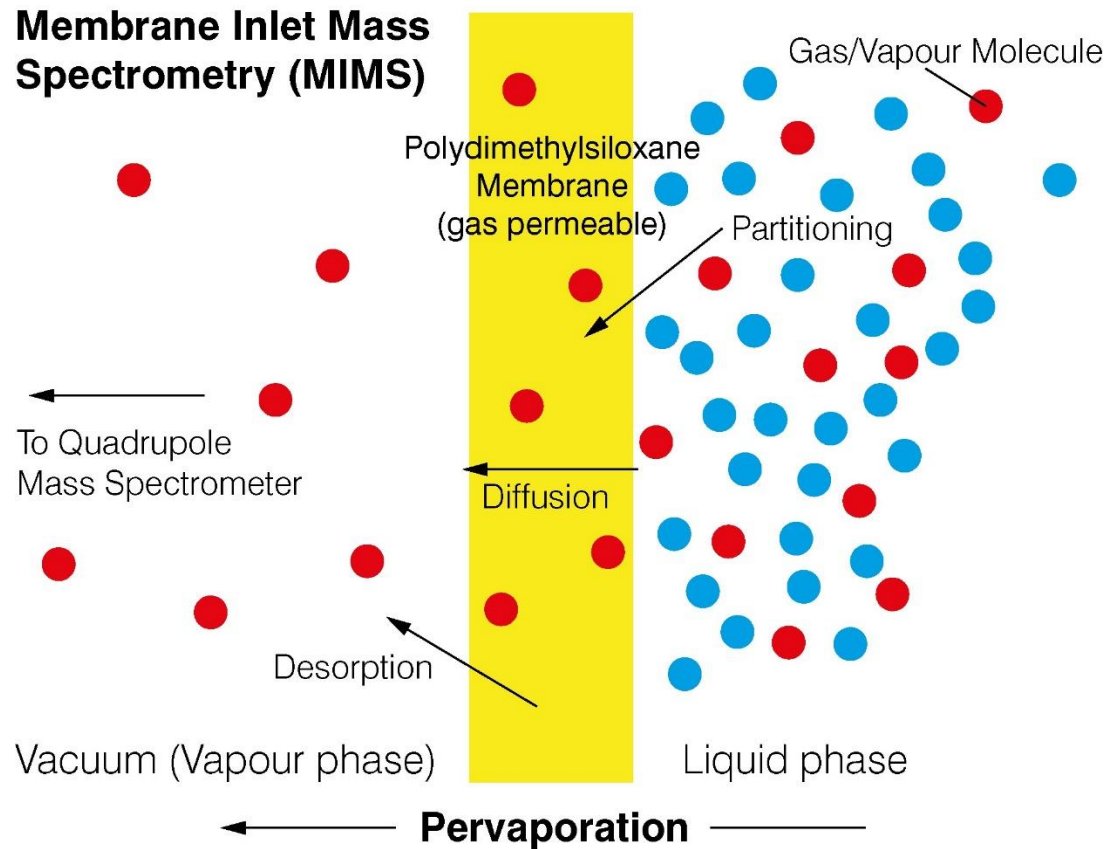

Typical enrichment factors w.r.t. N ₂	
CO ₂	12.0
CH ₄	3.2
C ₃ H ₈	13.6
CH ₃ OH	46.4
SO ₂	50.0
C ₃ H ₆ O	19.6
C ₆ H ₅ CH ₃	30.4

Dissolved Species Membrane Probe

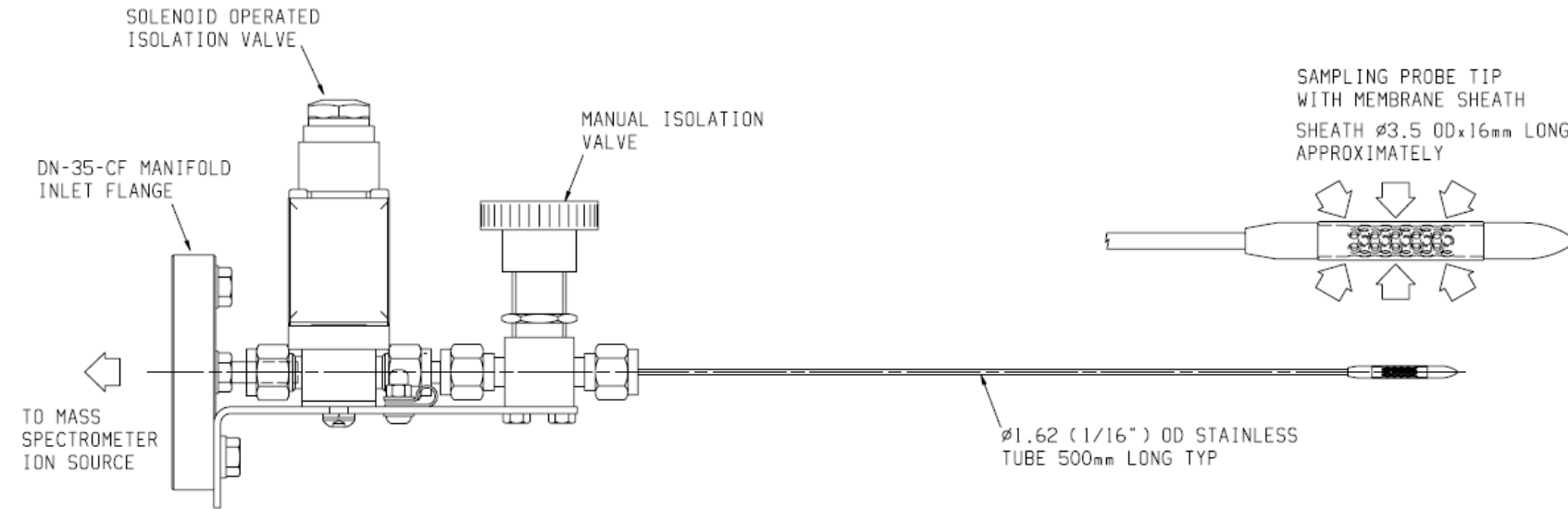

Flow-through Membrane Cell

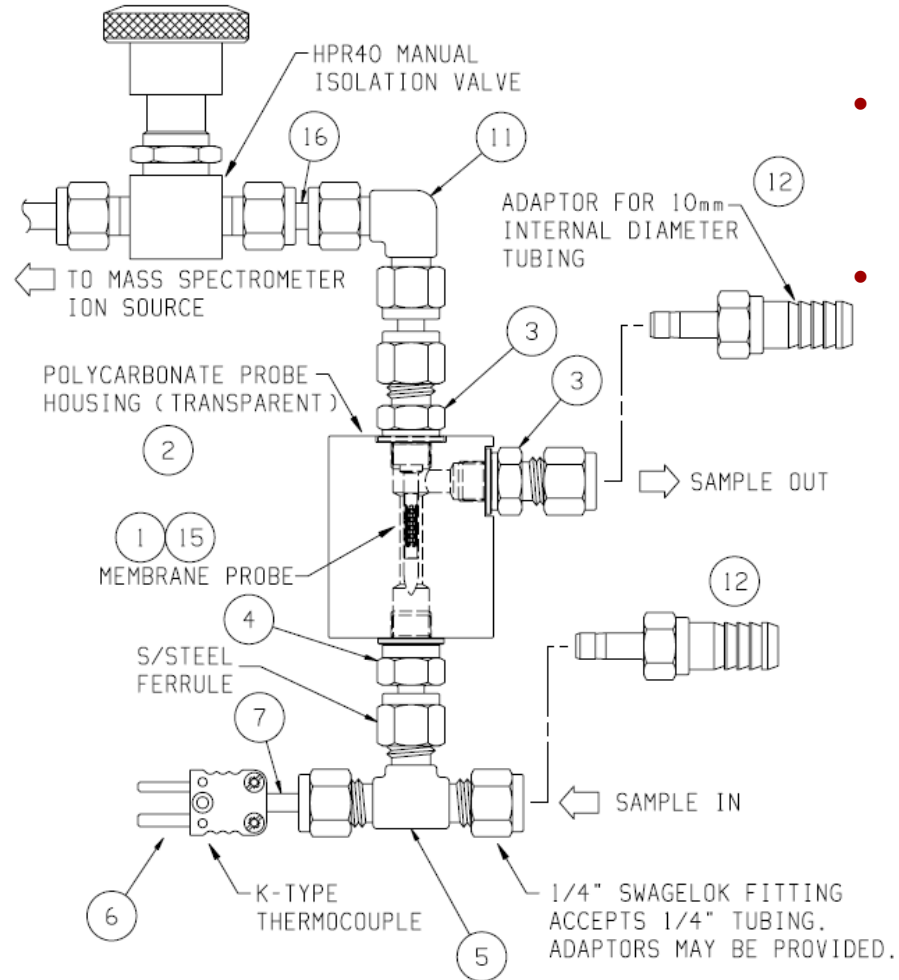

- Dissolved species flow-through membrane cell (with potential for integrated thermocouple).
- Includes liquid flow connections, ideal for circulation applications



Cuvette Style Cell

- Dual volume construction (25 and 50 ml) cuvette including liquid flow connections
- Integrated thermocouple and fluid agitation mechanism
- Ideal for algal biofuel studies and other aquatic or fermentation studies



Calibration Data

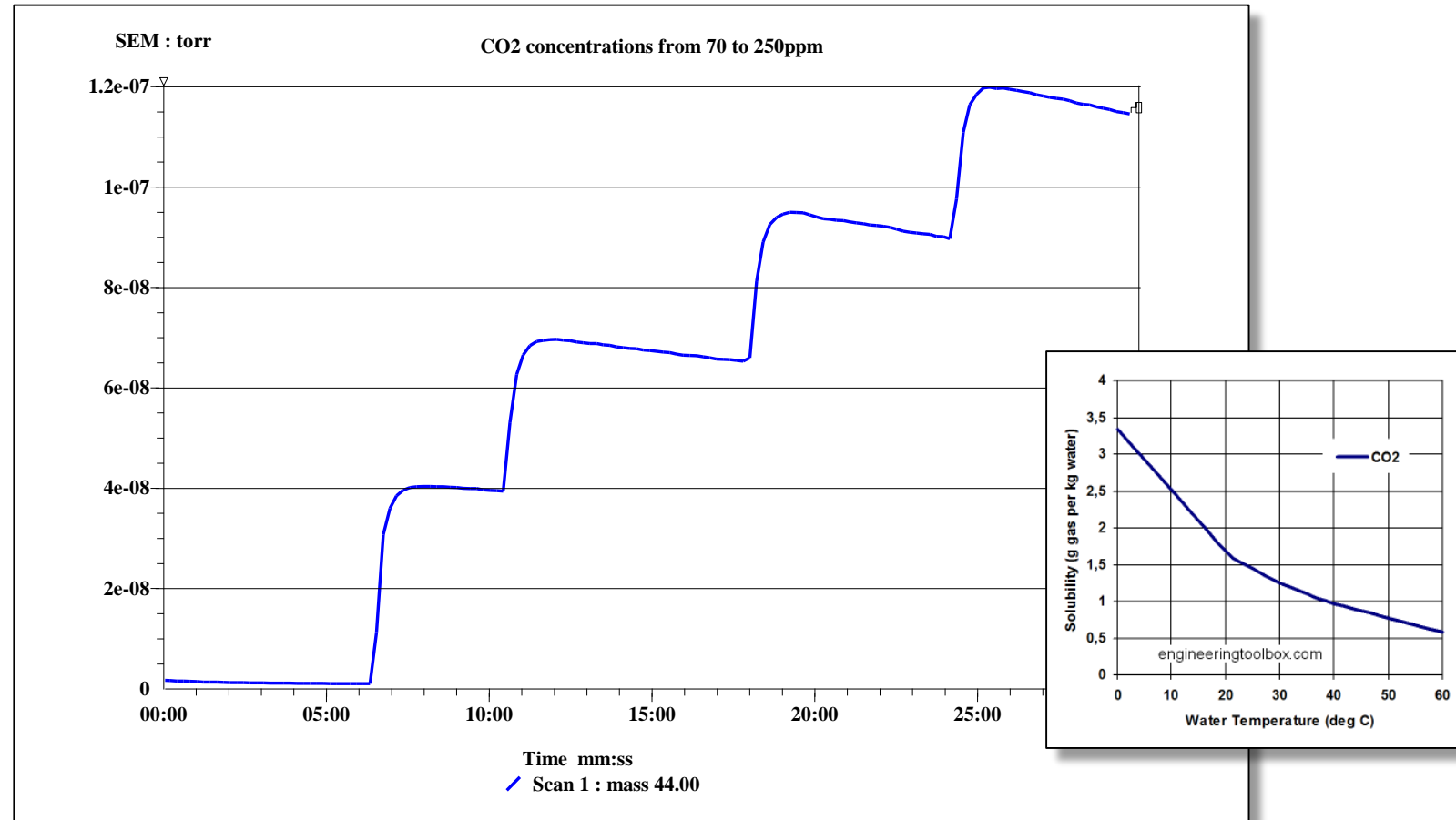

The figure shows the addition of 10mL aliquots of a CO₂-saturated H₂O solution (1.5g CO₂ per 1 kg H₂O at 23 deg C as per inset graph) to 200 mL pure H₂O. Therefore, the concentrations of CO₂ are approximately 0, 70, 140, 200, and 250 ppm for the 5 time steps shown.

Oceanic Studies

HPR-40 used to detect and analyse low level concentrations of DMS in British Columbian water (Dimethylsulphide, a trace substance implicated in global climate change and regulation).

The HPR-40 configured with a triple filter QMS provides detection levels into the parts per trillion range.

Corresponds to dilute DMS levels of ≤ 1 nmol/L

Influence of regional climate forcing on surface water $p\text{CO}_2$, DO_2/Ar and dimethylsulphide (DMS) along the southern British Columbia coast.

PD Tortell, A Merzouk, D Ianson, R Pawlowicz and D Yelland *Continental Shelf Research* 2012 **47** 119–132



Quadrupole Mass Spectrometers for Advanced Science

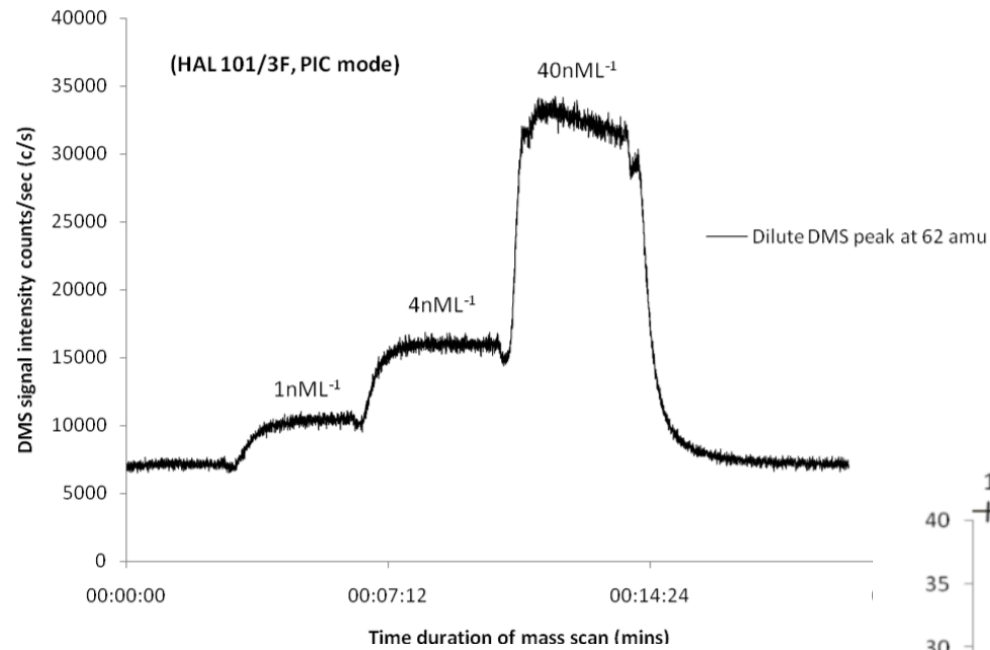

Data obtained shows sub ppb detection levels (≤ 60 ppt)

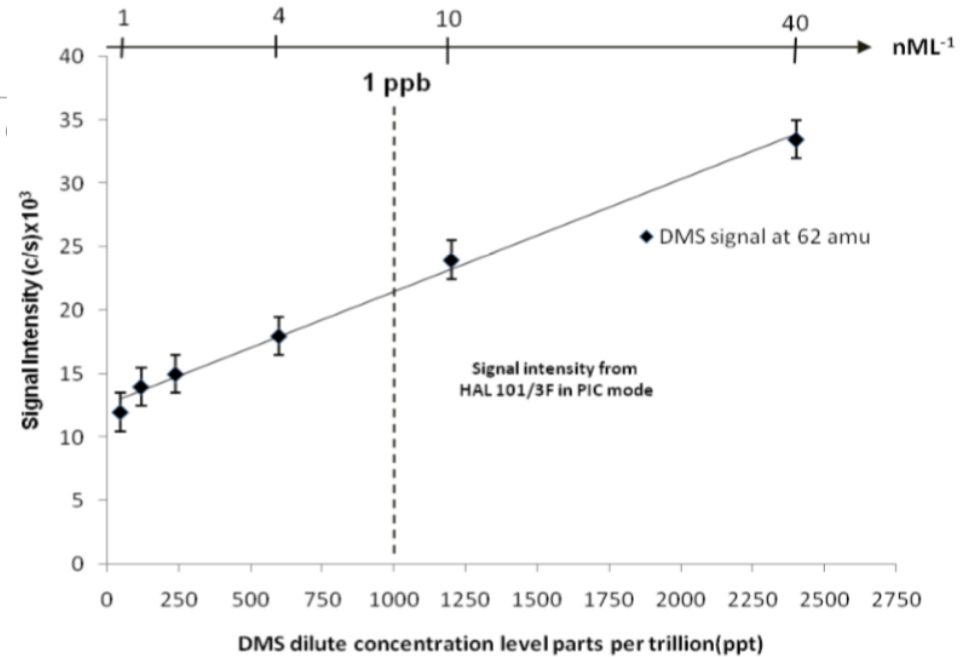

Data obtained with assistance from P.D. Tortell, Department of Botany, University of British Columbia

Denitrification study

Continuous real-time measurement of gases enabled the dynamics of the process to be investigated.

Concentrations of between 10 and 17 mmol/L were optimal.

Rate of denitrification dependant on cell concentration and required MIMS to model environmental conditions with low numbers of bacteria.

Denitrification by *Pseudomonas stutzeri* in a sterile lake water microcosm supplemented with succinate and nitrate.

JR Firth and C Edwards *Journal of Applied Microbiology* 2000 **88** 853-859

Data Obtained in Denitrification Studies

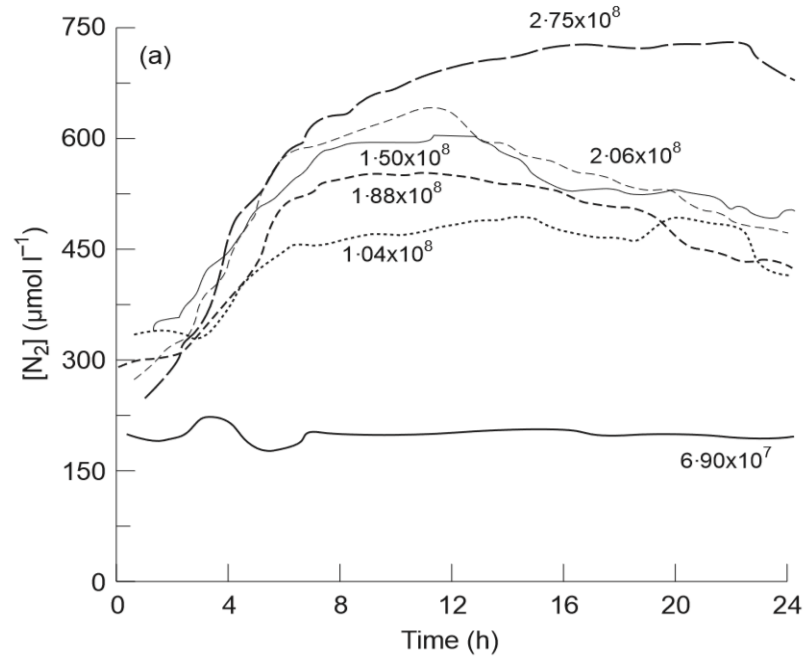

Data shows the effect of cell concentration on denitrification by *Pseudomonas stutzeri*. The lowest change in N_2 level measured was $40 \mu\text{mol l}^{-1}$ (Figure (a)).

Figure (b) demonstrates that a cell density in excess of $2 \times 10^8 \text{ cells ml}^{-1}$ did not unduly increase the amount of N_2 produced.

Data obtained by JR Firth and C Edwards, School of Biological Sciences, University of Liverpool, UK

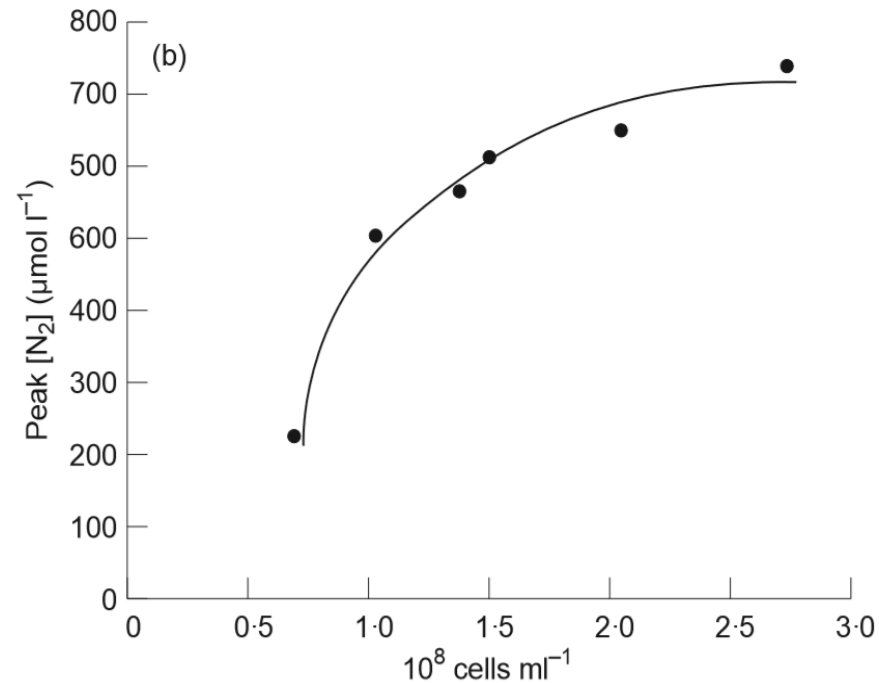

MASsoft Professional control software

- Template driven quick start operation
- Real time data display
- Mixed mode scanning including trend analysis
- Statistical analysis and peak integration
- Integrated mass spectral library



Easy Scans



Profile Scan
Display the shape of peaks across a range of masses



Bar Scan
Displays a histogram of peak intensities across a range of



MID Scan
Multiple Ion Detection Mode. Measures selected



Leak Detect Scan
Provides and audible and visual

Summary

- Membrane Inlet Mass Spectrometer for Dissolved Species Analysis
- Designed and manufactured by Hiden in the UK
- Configurable species probe inlets can be used for a wide variety of scientific applications

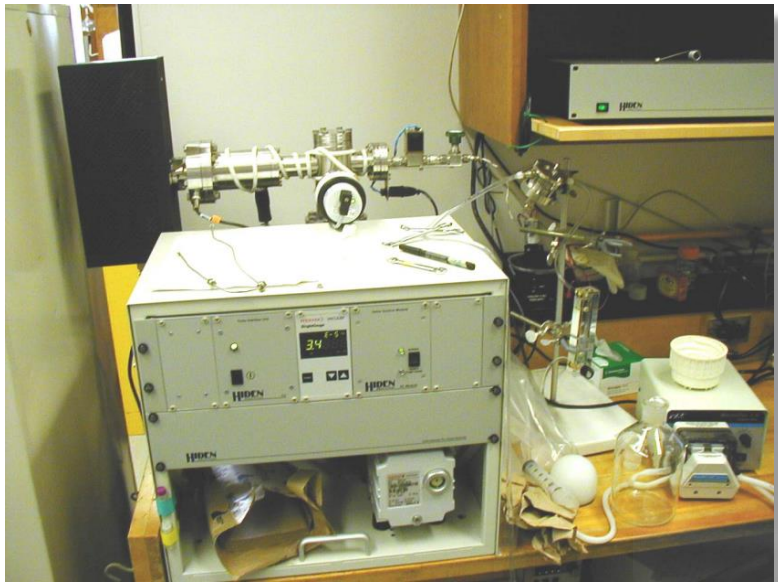

Academic References

- Denitrification by *Pseudomonas stutzeri* in a sterile lake water microcosm supplemented with succinate and nitrate. JR Firth and C Edwards *Journal of Applied Microbiology* 2000 **88** 853-859.
- Development of membrane inlet mass spectrometry for examination of fermentation processes. J-R Bastidas-Oyanedel, Z Mohd-Zaki, S Pratt, J-P Steyer and DJ Batstone *Talanta, The International Journal of Pure and Applied Analytical Chemistry* 2010 **83** 482-492.
- Influence of regional climate forcing on surface water pCO₂, DO₂ /Ar and dimethylsulfide (DMS) along the southern British Columbia coast. PD Tortell, A Merzouk, D Ianson, R Pawlowicz and D Yelland *Continental Shelf Research* 2012 **47** 119-132.
- High resolution measurement of Southern Ocean CO₂ and O₂/Ar by membrane inlet mass spectrometry. C Gu´eguen and PD Tortell *Marine Chemistry* 2007 **108** 184-194.
- Field Continuous Measurement of Dissolved Gases with a CF-MIMS: Applications to the Physics and Biogeochemistry of Groundwater Flow. E. Chatton, T. Labasque, J. de La Bernardie, N. Guihéneuf, O. Bour, L. Aquilina *Environ. Sci. Technol.* 2017, **51** (2) 846-854.

Hidden HPR-40 Users



廈門大學
XIAMEN UNIVERSITY

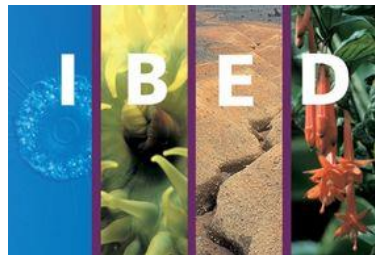

UNIVERSITY OF
EASTERN FINLAND



UNIVERSITY OF
LIVERPOOL

- Trent University
- Forest Research Institution (SCION)
 - Xiamen University
 - University of Kuopio
 - Cardiff University
 - University of Wales
 - Ricoh
 - University of Queensland
 - University of Newcastle
- University of California, Berkeley
 - Liverpool University
- Institute for Biodiversity and Ecosystem Dynamics
 - National Institute of Oceanography, Goa
 - GBA Laborgruppe
 - University of Rennes





Hiden Analytical Ltd.
420 Europa Boulevard
Warrington, WA5 7UN, England

www.HidenAnalytical.com

info@hiden.co.uk

Tel: +44 (0)1925 445 225

